

**Registered Office:**

Aluline Systems Pvt. Ltd.  
ONE BKC, 'B' Wing, 701, Plot No. C-66,  
G Block, Bandra Kurla Complex,  
Bandra (East), Mumbai - 400051.

**Administrative Office/Showroom:**

Aluline Systems Pvt. Ltd.  
B/102, Antop Hill Warehouse Company Ltd.,  
Barkat All Marg, Wadala (East),  
Near Dosti Acres, Mumbai 400 037.  
Call: +91 99872 18926

**Warehouse / R&D Centre:**

Vrundavan Complex,  
Opp. Satyam Petrol Pump,  
Mumbai - Nashik Highway,  
Sonale Village, Bhiwandi.

[contact@alulinesystems.com](mailto:contact@alulinesystems.com)  
[www.alulinesystems.com](http://www.alulinesystems.com)

**India Offices:**

Ahmedabad • Baroda • Calicut • Chennai • Delhi • Goa • Hyderabad • Kochi  
Ludhiana • Mumbai • Pune • Raipur • Sangli • Shimla • Surat

**International Offices:**

Dubai • Oman • Saudi Arabia (Jeddah)

## The Aluline Story

Two decades ago, a group of people stepped into the construction and fenestration business. With time, the amateurs of the industry blended themselves to become experts in their field, earning reputation within the architectural aluminium glazing industry by delivering high quality solutions in specified timelines that are cost effective. Year 2019, with a wealth of experience and expertise, specialising in the design of aluminium architectural building systems, ALULINE was established for providing a comprehensive range of architectural aluminium systems and products for the commercial and residential projects.

Successful collaborations with reputed global manufacturers enable us source the systems that offer latest infrastructure with highest precision and world class surface finishing.

The systems are carefully designed by our team of experts to achieve the highest efficiency. With its forward-thinking approach, the company is dedicated in delivering high quality solutions that are cost effective, within budget and in a particular time frame.

With the Headquarters in Mumbai, the company is equipped with the latest software and equipment and houses a fully experienced and knowledgeable technical team. These enable to offer a full in-house CAD operated design service and bespoke software packages to ensure cost effective and accurate solutions to the clients' requirements.

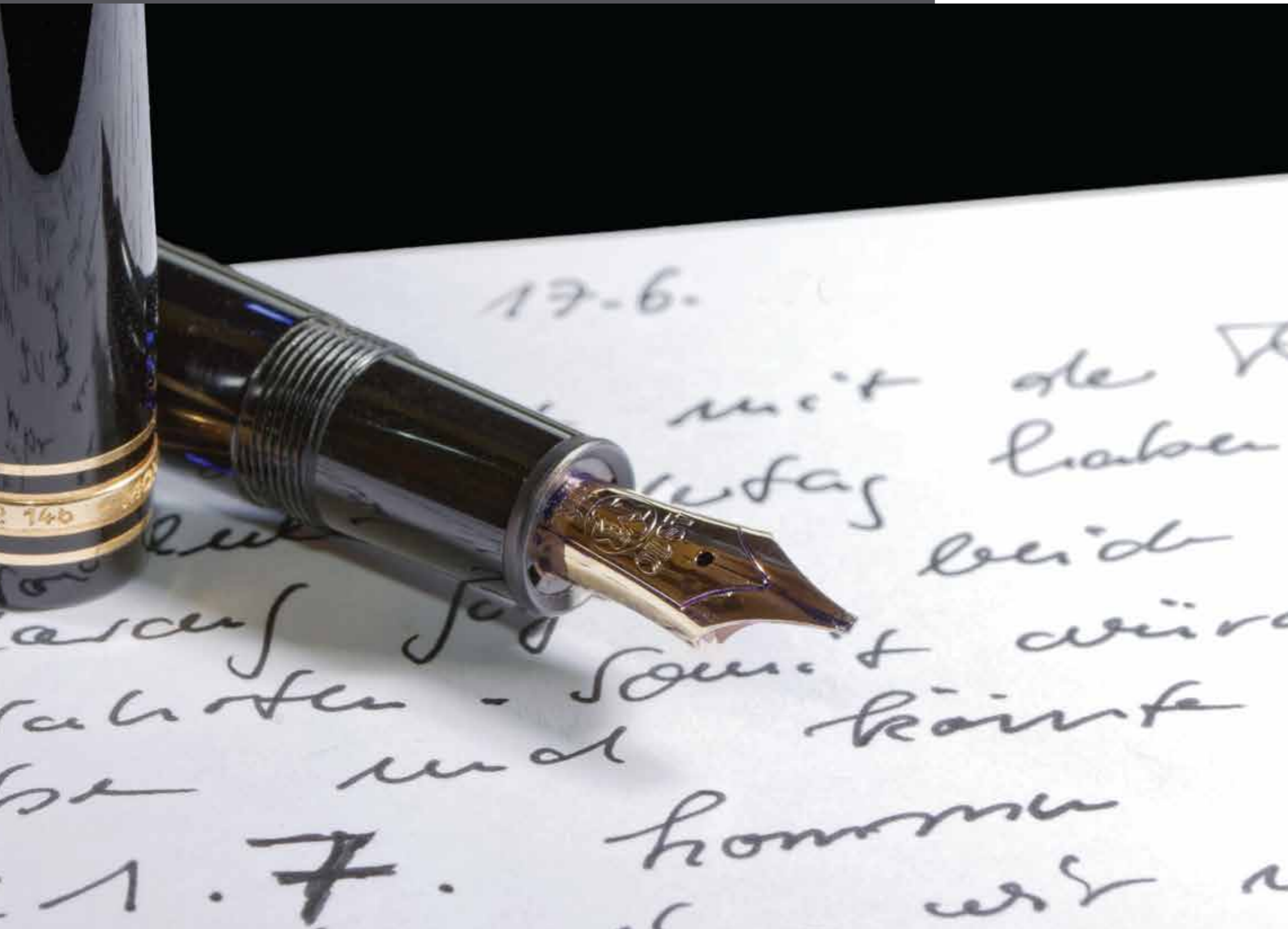



## Our Strength



### QUALITY

All our systems have been designed to the highest standards, to make sure they give maximum performance and have an extended life cycle. Care has been taken in identifying vendors who follow international practices in production be it aluminium profiles, hardware, accessories or gaskets.



### RESEARCH & DEVELOPMENT CENTRE

At ALULINE, it is our constant endeavour to upgrade our design to provide increased efficiency and accuracy resulting in a high-quality end product for which we have specially set up a research & development facility at Bhiwandi. This facility is equipped with state-of-the-art machinery for various processes related to superior quality output of the systems. This facility is also used to give training to our fabricators to educate them with our systems. Our end customers can be quality confident, because all our products have been painstakingly designed and tested to meet or exceed all the quality parameters for building requirements.

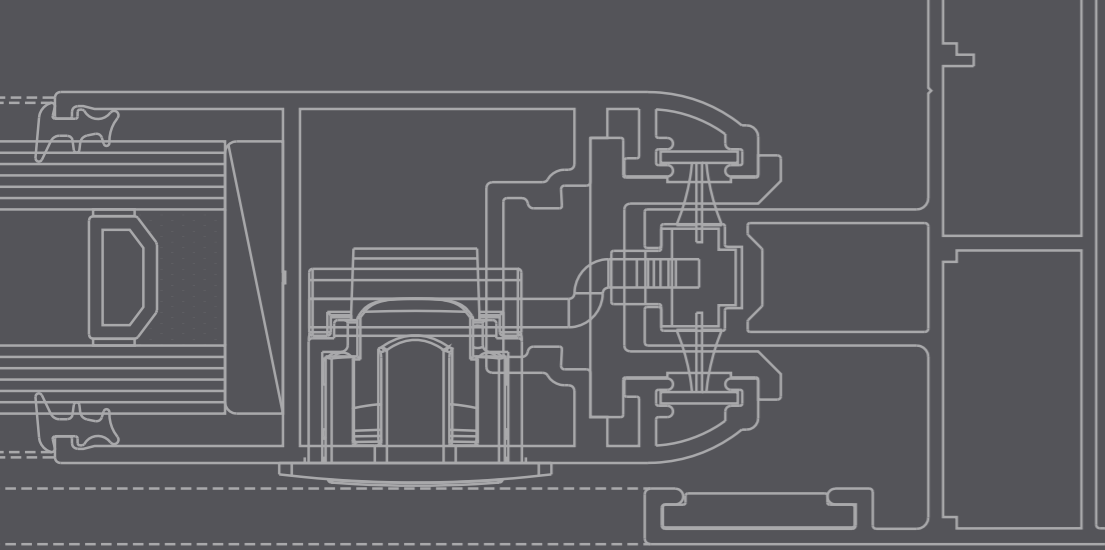

## EXPERIENCE CENTRE

We have compiled years of our experience to create an extensive showroom. Here we have not only displayed an array of systems to help our clients identify their needs but also our expert advisors are available on hand to answer their questions and guide them wherever necessary. Our most popular range of aluminium windows and doors are on show within our exclusive showroom in Mumbai.



## WAREHOUSE

We have a fully stocked, 13000 sq. ft. purpose-built warehouse based in Bhiwandi, strategically placed at the hub of the logistic network and close to our major transport partners thus offering the flexibility, capacity and capability of delivering our systems nationwide in the shortest possible time. Our warehouse space allows vast stock holding for project supplies as well as retail supplies.



## SUPPORT

Our philosophy is simple, we listen very closely to our client's needs and establish exactly what they expect and require from us, we then align our products and services to fully satisfy those requirements. Also, with all our departments acting as a team including estimation, design, sales and logistic support, ALULINE is a true 'one-stop-shop' for our clients' requirements.

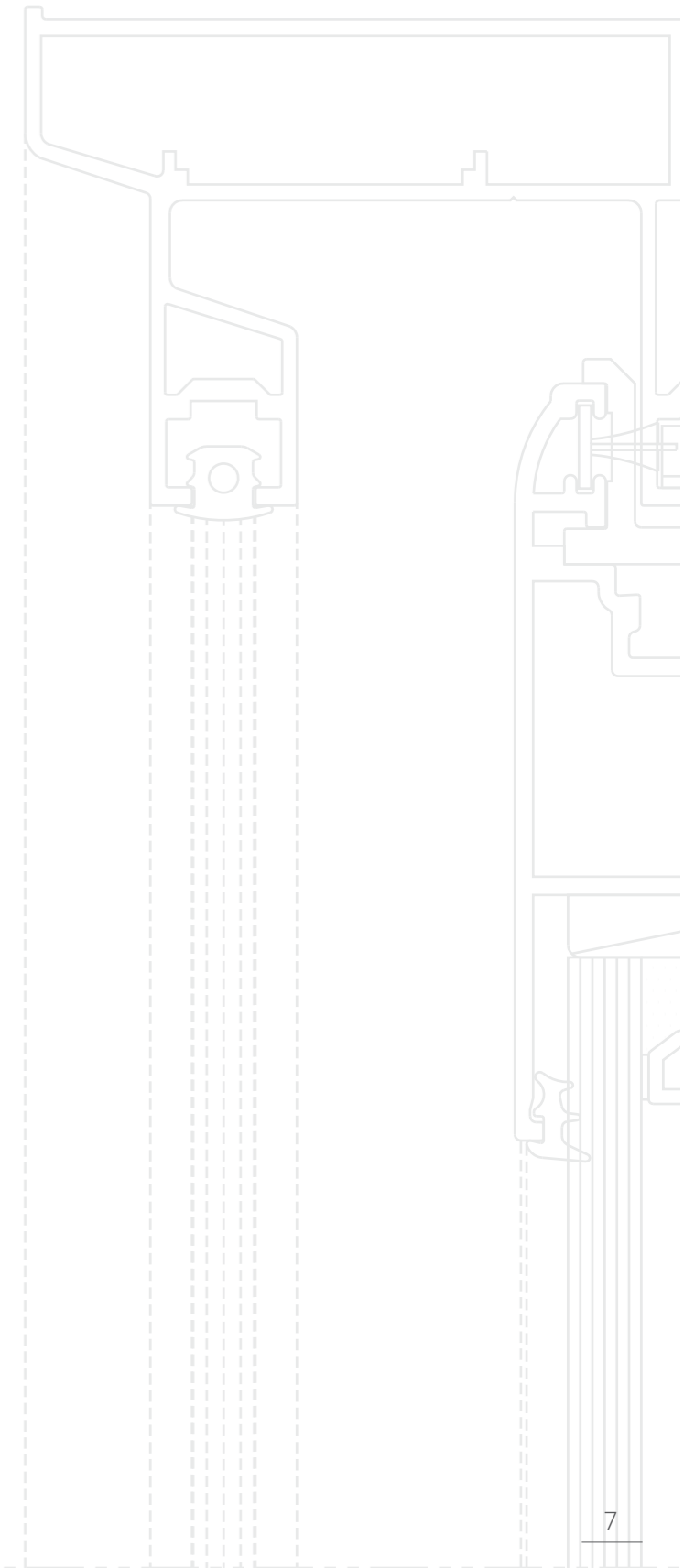

## INDEX

Λ38 Slimline	11
Λ28S Slimline	13
Λ28C Slimline	15
Λ28 Slimline	17
Λ3500	19
Λ3000	21
Λ6000 Invisible	23
Λ4000	25
Λ4000D	27
Λ22000	29

# A38 SLIMLINE

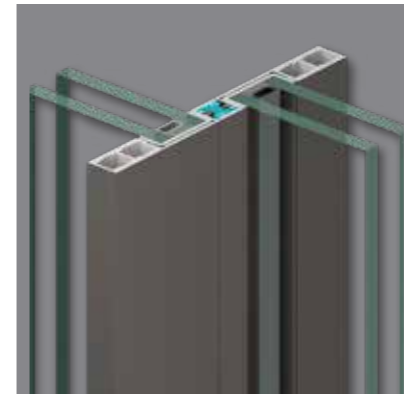
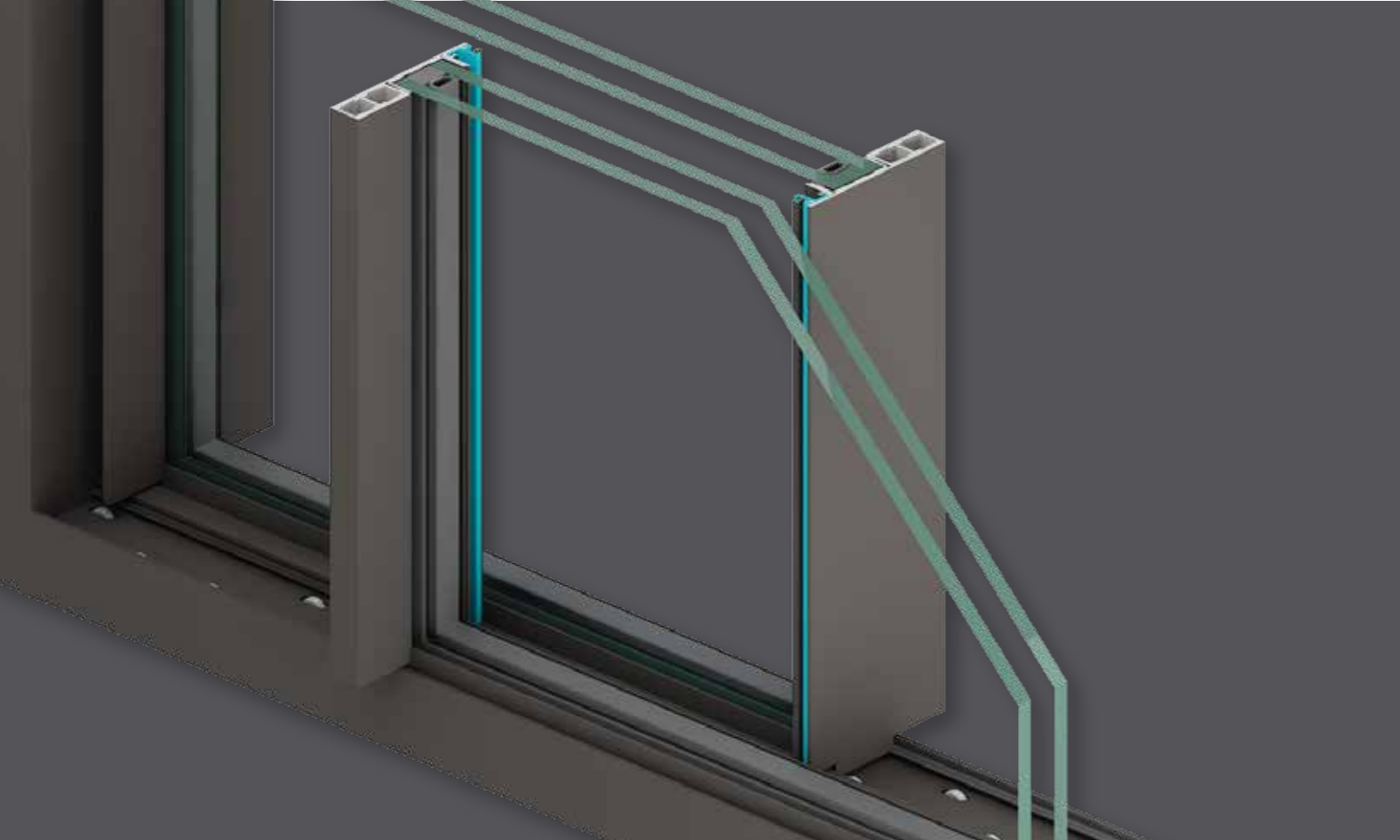

In this exquisite 'floor to ceiling series' the aluminium window frame and sash have been significantly reduced & have been crafted in a minimal design to lessen the number of visible frames and sash. This maximises the spans and openings of rooms to light and landscape and the windows transform into a large panoramic view. Regardless of the typology or design, A38 Minislim series offers double glazing as standard, making this a system which is a culmination of the widely employed modern design concept, ensuring maximum transparency and excellent performance using the latest and most advanced technology.

This series made from high-performance aluminium can endure heavy wind loads & ensures safety even when subjected to severe weather conditions.

## Technical Characteristics

### System Technical Specification

Profile Alloy	6063 - T6
Glass Thickness (mm)	38
Max Height Shutter (mm)	4000
Multi Locking	Yes
Max Sq.mtr/per Sash	6
Maximum Weight of each Shutter (Kgs)	500
Mosquito Mesh	Not Possible
Thermal Insulation	Yes

### Application & Profile Detail

Top & Side Frame Height (mm)	50	
Bottom Frame Height (mm)	60	
Frame Width (mm)	2T2S	125
	3T3S	191
Sightline at Interlock (mm)	20	
Center Meeting (mm)	2T4S	20





# A28S SLIMLINE



A28S Series aluminium sliding window is a unique horizontal opening solution, this sliding window allows its entire surrounding frame to be concealed with Marble, Granite, wood or any other type of flooring or wall panel used in the interior or exterior of the house. The exceptional finishes provide incomparable transparency on all four sides and the expansive openings offer maximum light with the fewest possible visible profiles. The glazing and surface options are infinite. This new window creates space, light and freedom. The architectural barrier between inside and out ceases to exist.

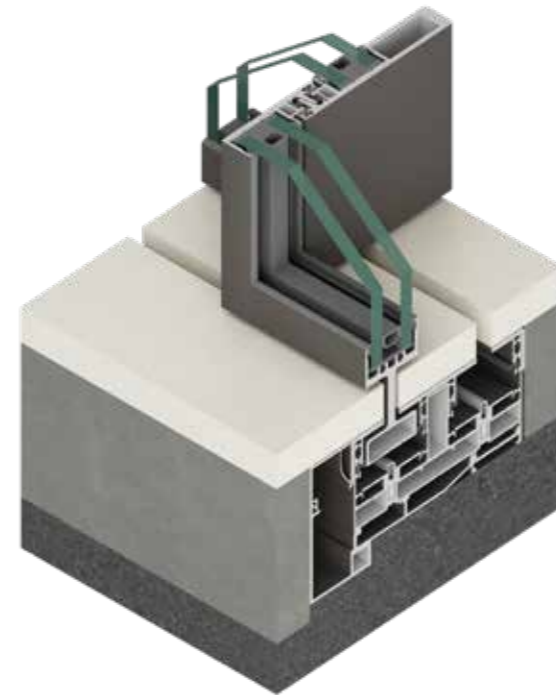

## Technical Characteristics

### System Technical Specification

Profile Alloy	6063 - T6
Glass Thickness (mm)	8, 13.5, 18, 28
Max Height Shutter (mm)	3400
Multi Locking	Yes
Max Sq.mtr/per Sash	6
Maximum Weight of each Shutter (Kgs)	350/500
Hidden Bottom	Possible
Corner Opening	Possible
Mosquito Mesh	Not Possible

### Application & Profile Detail

Top & Side Frame Height (mm)	52	
Bottom Frame Height (mm)	62	
Frame Width (mm)	2T2S	112
	3T3S	174
Sightline at Interlock (mm)	18	
Center Meeting (mm)	2T4S	18



# A28C SLIMLINE



Your home is a reflection of who you are. Let your vision and imagination dictate your style. Fall in love with the sleek lines and unobtrusive beauty of our stunning new A28 Concealed sliding window system. Apart from performance which is the basic DNA of all our systems, A28C offers a complete hidden track solution which creates the illusion of space and a seamless connection between the outdoors and indoors. They also offer great strength and security and our high-performance rollers deliver an effortless sliding function.

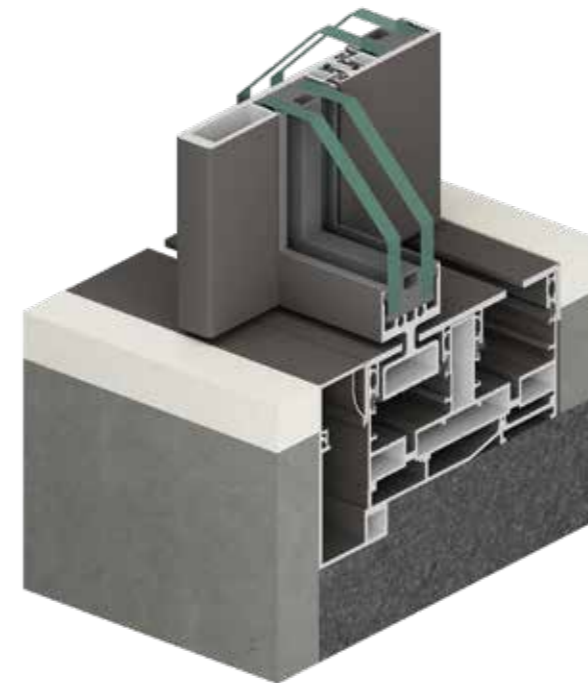

## Technical Characteristics

### System Technical Specification

Profile Alloy	6063 - T6
Glass Thickness (mm)	8, 13.5, 18, 28
Max Height Shutter (mm)	3400
Multi Locking	Yes
Max Sq.mtr/per Sash	6
Maximum Weight of each Shutter (Kgs)	350/500
Hidden Bottom	Possible
Corner Opening	Possible
Mosquito Mesh	Not Possible

### Application & Profile Detail

Top & Side Frame Height (mm)	52	
Bottom Frame Height (mm)	62	
Frame Width (mm)	2T2S	112
	3T3S	174
Sightline at Interlock (mm)	18	
Center Meeting (mm)	2T4S	18

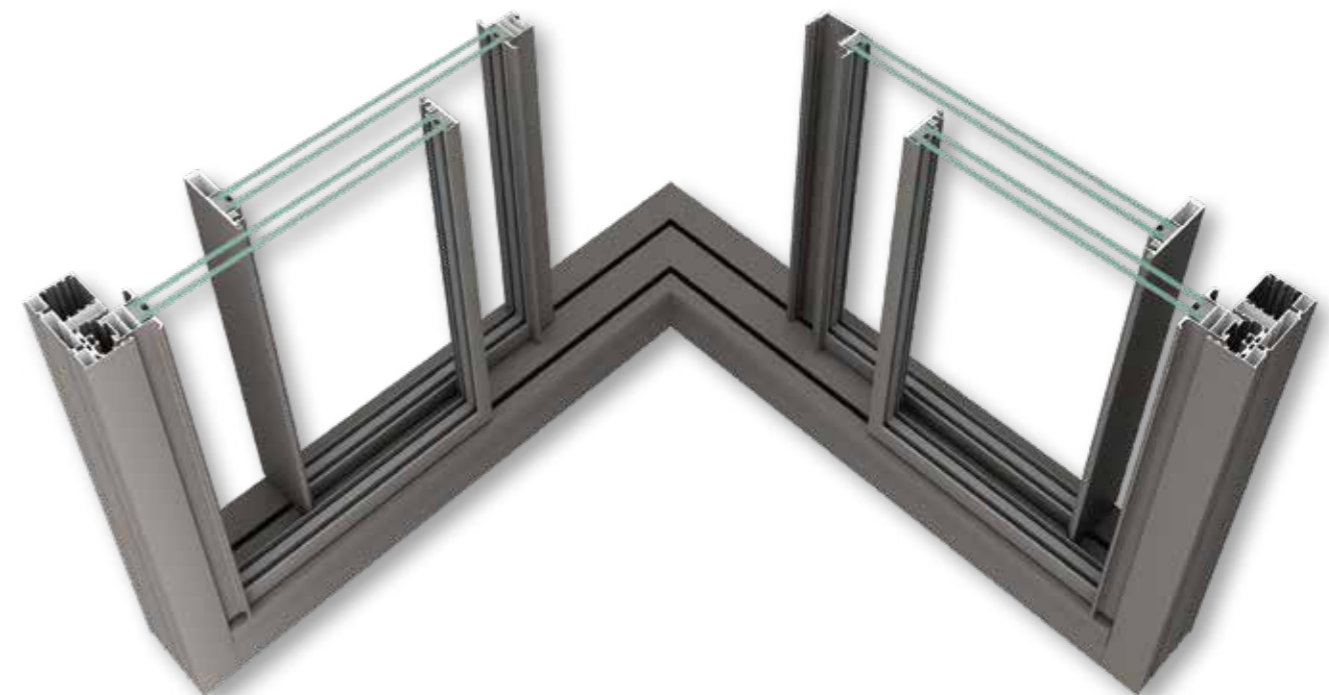



# A28 SLIMLINE



This remarkable series is developed keeping in mind the requirements of builders / developers and architects who need the most advanced Minimal systems at budgeted rates. This system can adapt to both, windows and doors. The robust design can deliver truly marvellous windows to the project and enhance the elevations to a very great extent. Large panels can be made in this system and effortless sliding can be expected since the trolleys are designed, manufactured and sourced from one of the finest companies in the world. The fabrication and assembly details have been well thought of so as to give the lowest effort that any Minimal system can offer.

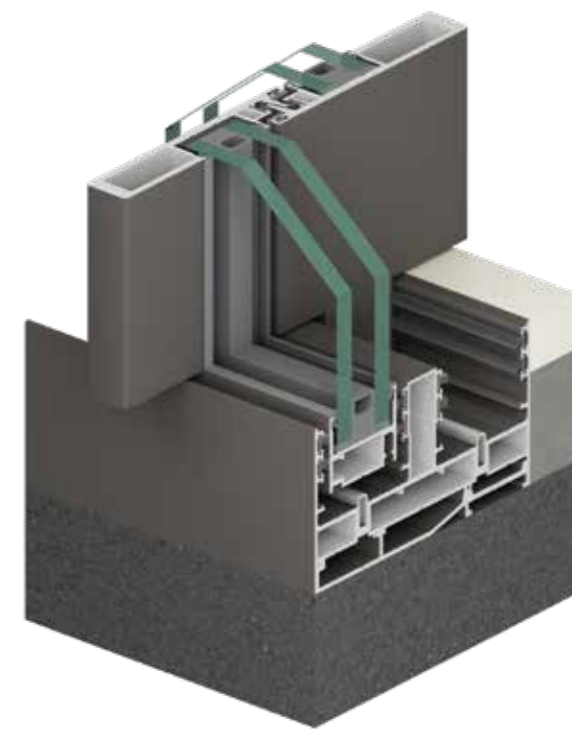

## Technical Characteristics

### System Technical Specification

Profile Alloy	6063 - T6
Glass Thickness (mm)	8, 13.5, 18, 28
Max Height Shutter (mm)	3400
Multi Locking	Yes
Max Sq.mtr/per Sash	6
Maximum Weight of each Shutter (Kgs)	350/500
Corner Opening	Possible
Mosquito Mesh	Not Possible

### Application & Profile Detail

Top & Side Frame Height (mm)	52	
Bottom Frame Height (mm)	62	
Frame Width (mm)	2T2S	112
	3T3S	174
Sightline at Interlock (mm)	18	
Center Meeting (mm)	2T4S	18





# A3500

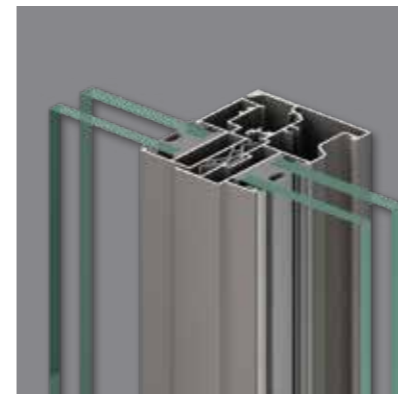

This marvelously designed slim series is the ideal solution for sliding doors which require aesthetic, performance & functionality. This series has been elaborated aiming to meet the highest standards in elegance, comfort, and performance. The interlocking profiles add a lot of glamour to the door system thanks to the slender form adapted in the design phase.

Its high wind resisting contrives makes it the ideal choice for sliding doors required for high rise residential buildings. If you love the elegant style of living, treat yourself with the excellent features from this series.

## Technical Characteristics

### System Technical Specification

Profile Alloy	6063 - T6
Glass Thickness (mm)	6, 8, 13.5, 22, 24
Max Height Shutter (mm)	2800
Multi Locking	Yes
Max Sq.mtr/per Sash	4.5
Maximum Weight of each Shutter (Kgs)	200
Corner Opening	Possible
Mosquito Mesh	Not Possible

### Application & Profile Detail

Frame Height (mm)	39	
Frame Width (mm)	2T2S	92
	3T3S	142
Sightline at Interlock (mm)	20	
Center Meeting (mm)	2T4S	58

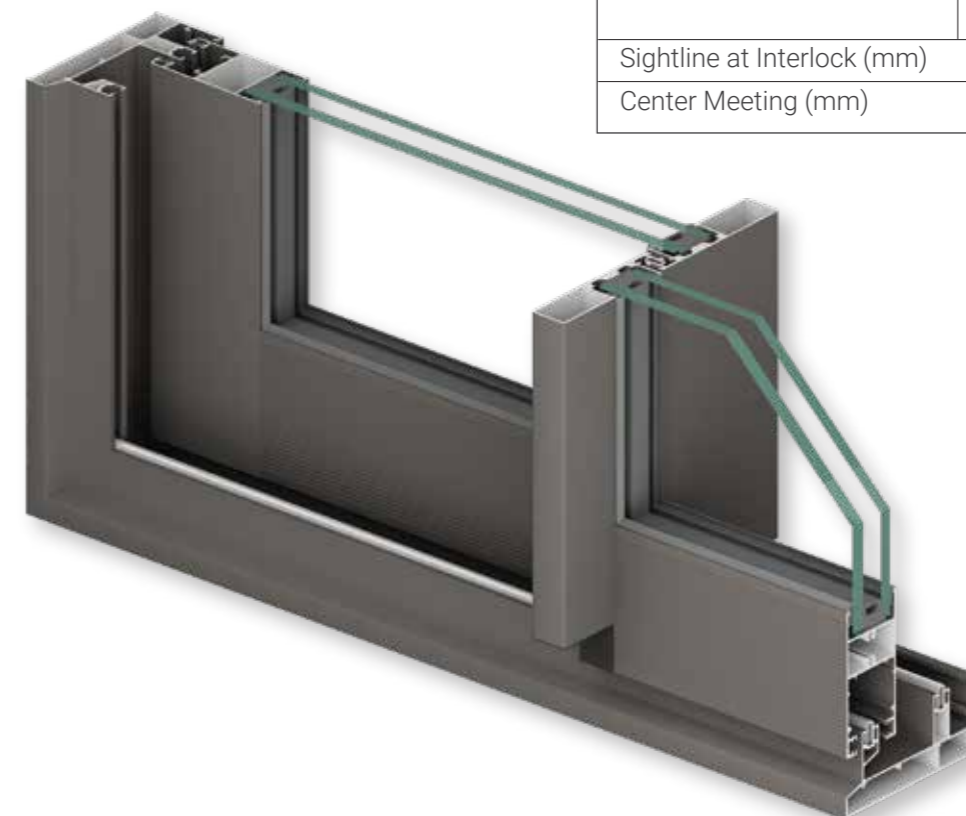



# A3000

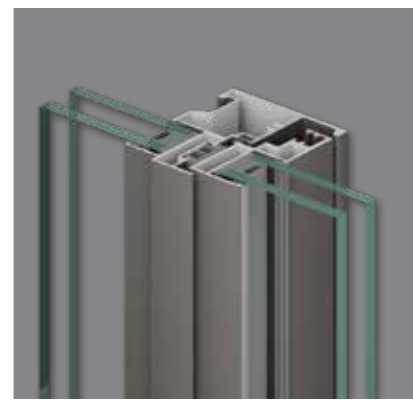

Our A-3000 series is considered by many to be the best in terms of aesthetics, quality, durability and performance, however, what really sets this series apart is that it is probably the only slim line series in this segment. The versatility of this series is unmatched since it offers a wide range of locking solutions such as single point locking & multipoint flush locking.

Keeping in line with the current requirement of the market wherein the Balconies are diminishing and windows are becoming an integral part of the elevation, this series is designed to merge with our fixed glass system at the bottom which doubles up as a railing thereby saving space and cost. This helps majorly when the window sill is not wide enough to cater to windows and railing separately.

## Technical Characteristics

### System Technical Specification

Profile Alloy	6063 - T6		
Glass Thickness (mm)	6, 8, 11.5, 22, 24		
Max Height Shutter (mm)	2400		
Multi Locking	Yes		
Max Sq.mtr/per Sash	3.6		
Maximum Weight of each Shutter (Kgs)	150		
Corner Opening	Possible		
Mosquito Mesh	Not Possible		

### Application & Profile Detail

Frame Height (mm)	39		
Frame Width (mm)	2T2S	83	
	3T3S	128	
Sightline at Interlock (mm)	20		
Center Meeting (mm)	2T4S	60	



# A60 INVISIBLE



A-60 Series is an ultra-slim-framed casement window, with super slim profiles which can transform an ordinary window opening into something quite spectacular. This masterpiece of design maximises the glass area with the outer and shutter frames concealed in the wall structure. This is a threshold design for improved weather resistance, and superior looks. This sleek window incorporates customised accessories and ensures the window is shut tight for security and weather resistance.

## Technical Characteristics

### System Technical Specification

Profile Alloy	6063 - T6
Glass Thickness (mm)	6, 8, 8.9
Max Height Shutter (mm)	2000
Multi Locking	Yes
Maximum Weight of each Shutter (Kgs)	60
Inside Opening	Not Possible
Outside Opening	Possible
Double Shutter Opening	Not Possible
<b>Application &amp; Profile Detail</b>	
Frame Height (mm)	57
Frame Width (mm)	52
Outside Shutter Width (mm)	67

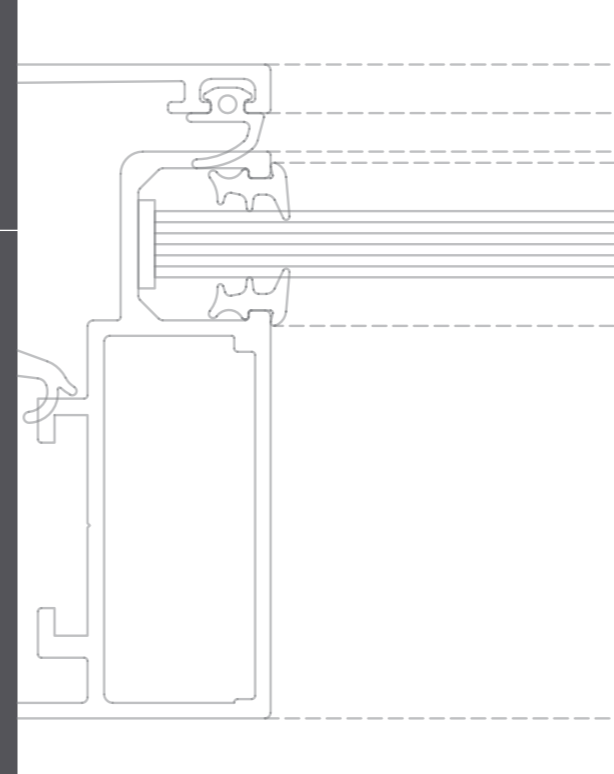

# A4000



The A-4000 series offers all that you would expect, and more, from a budget casement window system. Specifically designed to be used in modern bathrooms, this series can also be used for small openings in bedrooms, common areas and other places which require 100% ventilation. This series' windows look excellent and also reduce noise and dust infiltration dramatically. It is a perfect option for commercial windows since it offers an unparalleled value for money.

## Technical Characteristics

### System Technical Specification

Profile Alloy	6063 - T6
Glass Thickness (mm)	6, 8, 11.5, 22
Max Height Shutter (mm)	2000
Multi Locking	Yes
Maximum Weight of each Shutter (Kgs)	50
Tilt & Turn	Possible
Inside Opening	Possible
Outside Opening	Possible
Double Shutter Opening	Possible

### Application & Profile Detail

Frame Height (mm)	46
Frame Width (mm)	37
Inside Shutter Width (mm)	63
Outside Shutter Width (mm)	87



# A4000D



Our A 4000D series bears a retro classic design which never goes out-dated. These doors are a beautiful addition to any home that complement both modern and traditional home styles. Some of the advantages of these doors are that they are easy to install, economical, good looking, require very low maintenance and can be available in various configurations and finishes. These doors are much slimmer than the conventional door systems available locally.

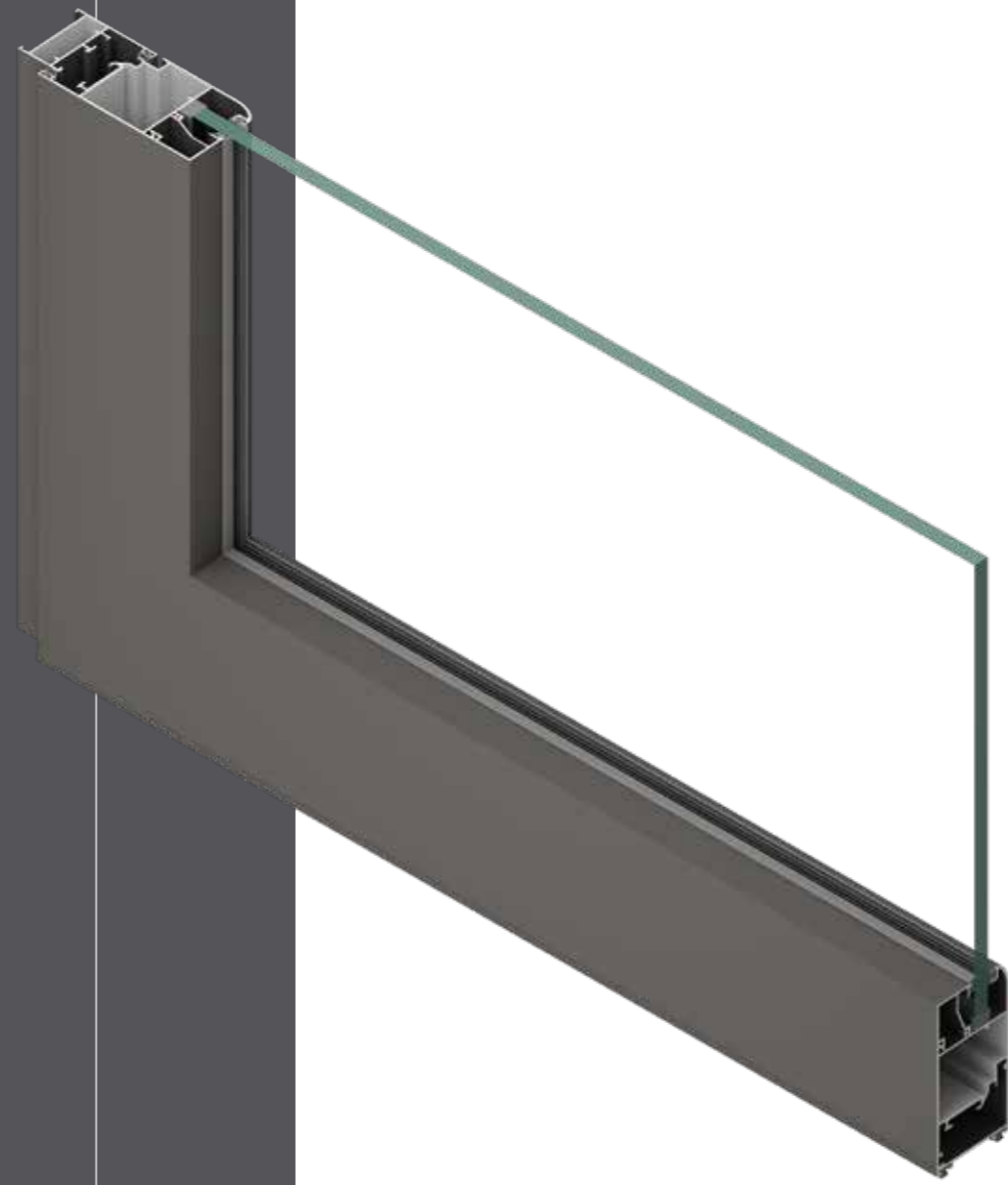

## Technical Characteristics

System Technical Specification	
Profile Alloy	6063 - T6
Glass Thickness (mm)	6, 8, 11.5, 22
Max Height Shutter (mm)	2800
Multi Locking	Yes
Maximum Weight Of Each Shutter (Kgs)	100
Inside Opening	Possible
Outside Opening	Possible
Double Shutter Opening	Possible
Application & Profile Detail	
Frame Height (mm)	46
Frame Width (mm)	37
Inside Shutter Width (mm)	87
Outside Shutter Width (mm)	87
Door Bottom Height (mm)	91



# A2200 BUDGET SERIES

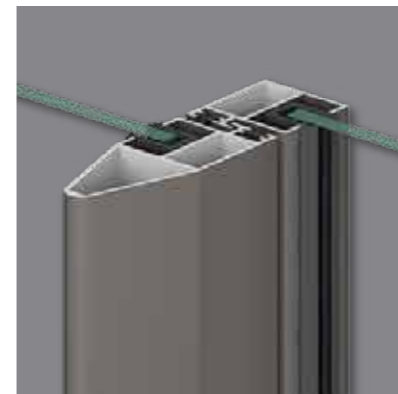

This system has been designed specially for developers who want the perfect combination of budget, performance and aesthetics. The new A2200 budget series offers unmatched beauty and performance, thanks to the high-class system engineering and imported rollers. To meet the demands of our domestic environment, our A2200 profiles and hardware ensure reliable, smooth operation combined with streamlined and efficient framing solutions to inspire great architectural outcomes

## Technical Characteristics

### System Technical Specification

Profile Alloy	6063 - T6		
Glass Thickness (mm)	5, 6		
Max Height Shutter (mm)	1800		
Multi Locking	Not Possible		
Max Sq.mtr/per Sash	2.2		
Maximum Weight of each Shutter (Kgs)	40/60		
Mosquito Mesh	Possible		
<b>Application &amp; Profile Detail</b>			
Frame Height (mm)	35		
Frame Width (mm)	2T2S	54	
	3T3S	83	
Sightline At Interlock (mm)	25		
Center Meeting (mm)	2T4S	116	



# EXPERIENCE CENTRE



At Aluline we believe that offering premium quality products is not enough to truly stand out in a competitive market. Hence, our products are designed to be the best in terms of aesthetics, quality, durability, performance and value for money. However, what really sets us apart is the service that we offer and our focus on customer satisfaction. Many well-respected architect practices have come to rely on our expertise and problem-solving capability during the design phase of a project. As specialists in our field, our highly experienced design team works closely with the clients to ensure that the finished building is as close as possible to their original vision.



Our aim is to exceed the expectations of every architect, contractor and householder and we make it possible by giving our unparalleled attention to the fine details throughout every project. When you are choosing the windows and doors for your project, we understand that you expect those windows and doors not only to look great, but to be durable, reliable, warm and secure for many years to come. All Aluline products are made with only the highest quality materials and components, the manufacturing process of the same is subjected to the most stringent quality control processes that are second to none.



ACTUAL SHOWROOM IMAGES

## SERIES COMBINATIONS

### Λ2200 SERIES

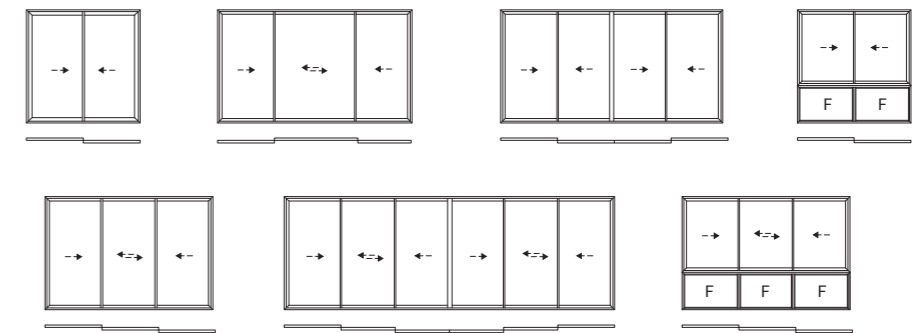

### Λ3000 SERIES

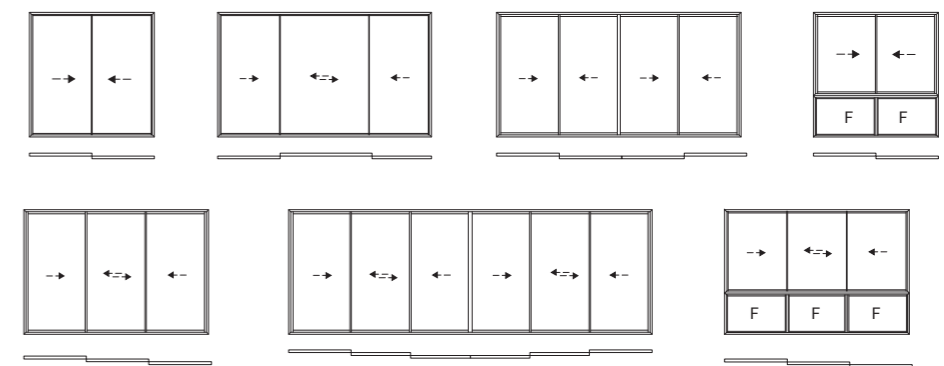

### Λ3500 SERIES

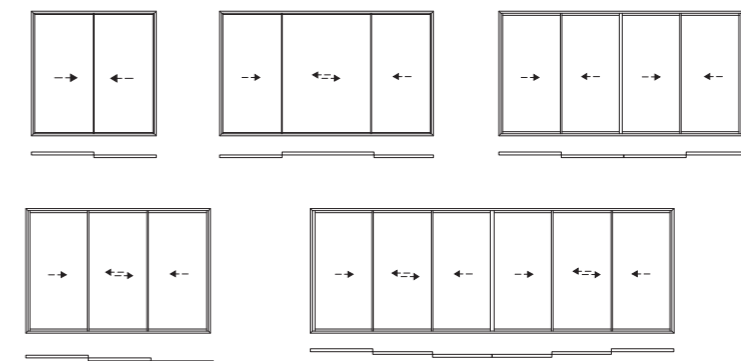

### Λ28 / Λ28C / Λ28S SERIES

